

# FEREX 4.034

Digital fluxgate magnetometer with  
4-channel data logger



## **Precise detection of geomagnetic anomalies**

The FEREX is a vertical gradient fluxgate magnetometer that measures the deformation of the earth's magnetic field evoked by ferromagnetic objects. Magnetometers are suitable for the detection of ferromagnetic metals like iron, steel or nickel. Normally the detection depth of magnetometers is larger compared to active EMI detectors, but it varies and depends on the object's mass and its magnetic properties.

The FEREX 4.034 can be used either in direct meter mode or in data recording mode. Four channels for data recording allow the FEREX 4.034 to be expanded into a multi probe holder system for large area survey. The device offers the possibility to connect alternative sensors and GNSS systems via a serial interface. This allows precise navigation and geo-referencing of the recorded data.

# Benefits and operation principle

## The benefits:

- **Highest sensitivity:** Magnetometer with tension band technology – provides sensor alignment for lifetime. Improved signal-to-noise ratio.
- **Precise detection:** Detects ferrous materials/UXO e.g., bombs, shells, projectiles, sub-ammunitions as well as underground infrastructure such as tunnels.
- **Various filters:** Enables the search under power lines, along fences, pipelines and railway tracks. High-pass and low-pass filter.
- **Comfortable operation:** Navigation screen with various navigation modes. 3.5" color sunlight readable display. Managing large survey areas consisting of multiple survey grids. Definition of various survey grid layouts by defining or importing polygon positioning data.
- **Expandable:** Data logging of up to 4 FOERSTER fluxgate sensor channels (differential and absolute value)
- **Adaptive:** Serial interface to link various GNSS systems or odometer. Implemented tool to edit customized GNSS-drivers.

- **Software:** DATA2LINE for project definition, post processing and evaluation of recorded data. Integrated stake-out function using imported DATA2LINE object and position lists.
- **Optional equipment:** Multi probe holder for up to 8 fluxgate probes. Wheel set, GNSS antenna mount, borehole detection kit, waterproof probe cables up to 100 m, headphone.

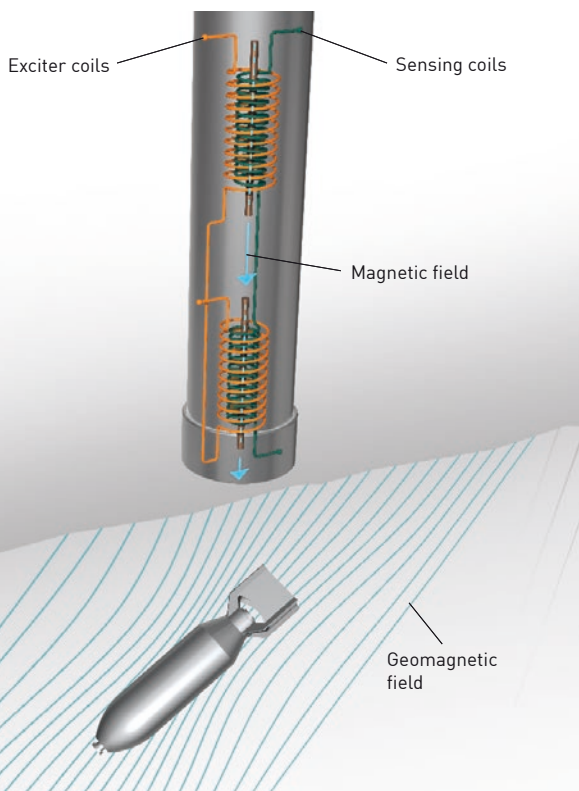

## Passive magnetometer methods

These methods are ideal for detecting ferromagnetic metals. Highly responsive passive sensors measure the Earth's homogeneous magnetic field and accurately recognize any disturbances in this field caused by nearby ferromagnetic components.

The position, orientation and mass of the metal object are determined by analyzing the anomalies in the magnetic field. These can be recorded or sent as acoustic or optical alerts to the operator, who then uses them to locate the object.

Since soils and infrastructure elements also carry their own magnetic signatures, highly sensitive magnetometers can be used in the context of archaeological and geological surveys. A distinction is made between absolute probes, which display the Earth's magnetic field including possible anomalies, and differential probes, which neutralize the Earth's magnetic field and display only the effect of the magnetic anomaly. FOERSTER supplies highly sensitive (fluxgate) magnetometer probes in both absolute and differential arrangements.

## Technical data

FEREX 4.034	
Weight	4.1 kg complete detector incl. batteries 12.1 kg complete detector set in case
Dimensions	FEREX – 1270 x 145 x 850 mm (H x W x D) Case – 989 x 415 x 157 mm (H x W x D)
Display	3.5" LCD with adjustable backlight, sunlight readable
Memory	32 GB SD card
Interfaces	4 x analog fluxgate gradiometer, 1 x serial
Temperatur range	Operation: -37 °C to +71 °C; -99 °F to +160 °F (ambient temperature) Stock: -57 °C to +71 °C; -135 °F to +160 °F
Power supply	4 x 1.5 V alkaline batteries (LR20) or 4 x 1.2 V NiMH (HR20)
Battery size	IEC LR20/HR20 - ANSI „D“
Battery lifetime	1 probe, continuous operation > 8 hrs
Measuring ranges in FEREX mode	8 linear ranges: $\pm 3$ nT to 10,000 nT and 1 logarithmic range
Sampling rate	900 Hz each channel
Resolution	24 bit ADC
Protection grade	IP 65

Probe MG-10-550	
Type	Fluxgate gradiometer
Base distance	550 mm
Application area	$\pm 62,500$ nT
Measuring range	$\pm 10,000$ nT gradient, $\pm 62,500$ nT absolute
Reference point	97.5 mm from end of probe rod, 4 mm outside symmetry axis
Declination	$\pm 3$ nT
Noise	<40 pT $\sqrt{\text{Hz}}$ @ 1 Hz
Cut-off frequency	230 Hz
Temperature drift	<1 nT/K
Uncertainty of measurement	<2 % ref. $\pm 10,000$ nT
Linearity	<1 nT referred to maximum measuring range
Protection grade	IP 68, 100 m with optional sealing plug
External dimensions	Diameter 39.4 mm (with protective cap), probe length 750 mm, base distance 550 mm

Certifications	
MIL-Standards certifications	MIL-STD 810G Method 514.6, Procedure I, Random Vibration MIL-STD 810G Method 516.6, Procedure I, Mechanical Shock MIL-STD 810G Method 516.6, Procedure IV, Transit Drop Test MIL-STD 810G Method 501.5, Procedure I, High Temperature MIL-STD 810G Method 502.5, Procedure I, Low Temperature MIL-STD 810G Method 503.5, Procedure I-C, Temperatur Shock MIL-STD 810G Method 506.5, Procedure I, Blowing Rain AEODP-7 Edition B, Annex A-1
NATO Stock Number (NSN)	6665-12-410-0251

## Worldwide sales and support offices



### Headquarters

- Institut Dr. Foerster GmbH & Co. KG, Germany

### Subsidiaries

- FOERSTER Tecom, s.r.o., Czech Republic
- FOERSTER France SAS, France
- FOERSTER Italia S.r.l., Italy
- FOERSTER U.K. Limited, United Kingdom
- FOERSTER (Shanghai) NDT Instruments Co., Ltd., China
- FOERSTER Instruments India Pvt. Ltd., India
- FOERSTER Japan Limited, Japan
- NDT Instruments Pte Ltd, Singapore
- FOERSTER Middle East, UAE
- FOERSTER Instruments Inc., USA

The FOERSTER Group is being represented by subsidiaries and representatives in over 60 countries – worldwide.

### Institut Dr. Foerster GmbH & Co. KG

#### Business Unit Detection & Security

In Laisen 70

72766 Reutlingen

Germany

+49 7121 140 0

sales.ds.de@foerstergroup.com

